

# Powercore®

## SQUAT RACK

### IMSQ50

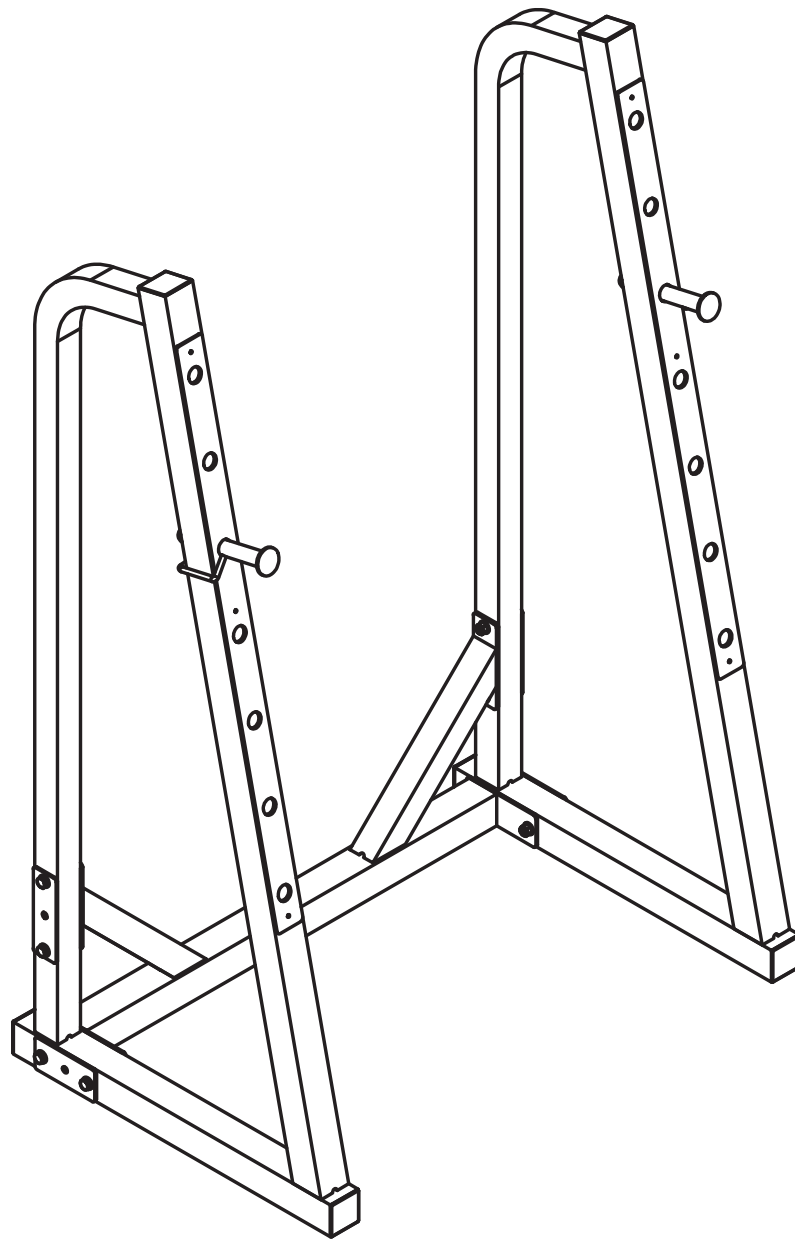

#### **CAUTION!**

Read all precautions and instructions in this manual before using this equipment.

20200916-V1.0

# **IMPORTANT SAFETY NOTICE**

## **PRECAUTIONS**

This exercise machine is built for optimum safety. However, certain precautions apply whenever you operate a piece of exercise equipment. Be sure to read the entire manual before you assemble or operate your machine. In particular, note the following safety precautions:

1. **Keep children and pets away from the machine at all times. DO NOT leave children unattended in the same room with the machine.**
2. Only one person at a time should use the machine.
3. If the user experiences dizziness, nausea, chest pain, or any other abnormal symptoms, STOP the workout at once. CONSULT A PHYSICIAN IMMEDIATELY.
4. Position the machine on a clear, leveled surface. DO NOT use the machine near water or outdoors.
5. Keep hands away from all moving parts.
6. Always wear appropriate workout clothing when exercising. DO NOT wear robes or other clothing that could become caught in the machine. Running or aerobic shoes are also required when using the machine.
7. Use the machine only for its intended use as described in this manual. DO NOT use attachments not recommended by the manufacturer.
8. Do not place any sharp object around the machine.
9. Disabled person should not use the machine without a qualified person or physician in attendance.
10. Before using the machine to exercise, always do stretching exercises to properly warm up.
11. Never operate the machine if the machine is not functioning properly.

**WARNING: BEFORE BEGINNING ANY EXERCISE PROGRAM, CONSULT YOUR PHYSICIAN. THIS IS ESPECIALLY IMPORTANT FOR INDIVIDUALS OVER THE AGE OF 35 OR PERSONS WITH PRE-EXISTING HEALTH PROBLEMS. READ ALL INSTRUCTIONS BEFORE USING ANY FITNESS EQUIPMENT. WE ASSUME NO RESPONSIBILITY FOR PERSONAL INJURY OR PROPERTY DAMAGE SUSTAINED BY OR THROUGH THE USE OF THIS PRODUCT.**

**SAVE THESE INSTRUCTIONS.**

# ASSEMBLY INSTRUCTION

## Tools Required Assembling the Machine:

Adjustable Wrench and Allen Wrench

### STEP 1 (See Diagram 1)

- A.) Attachs a Support Frame (#2) to a Upright Beam (#1). Secure the bottom with one M10×3 1/4" Bolt (#9) two Ø 3/4" Washers (#12),and one M10 Nuts (#13). Secure the bottom with one M10×2 7/8" Bolt (#10) one Ø 3/4" Washers (#12). Secure the top with two M10×2 7/8" Bolt (#10) one Long Bracket (#3).four Ø 3/4" Washers (#12) and two M10 Nuts (#13).
- B.) Repeat the above step A to install the other Upright Beam and Support Frame
- C.) Securely tighten all the nut and bolts previously installed.Insert two Bar Catches(#6)&(#7) to the desired holes at the same height

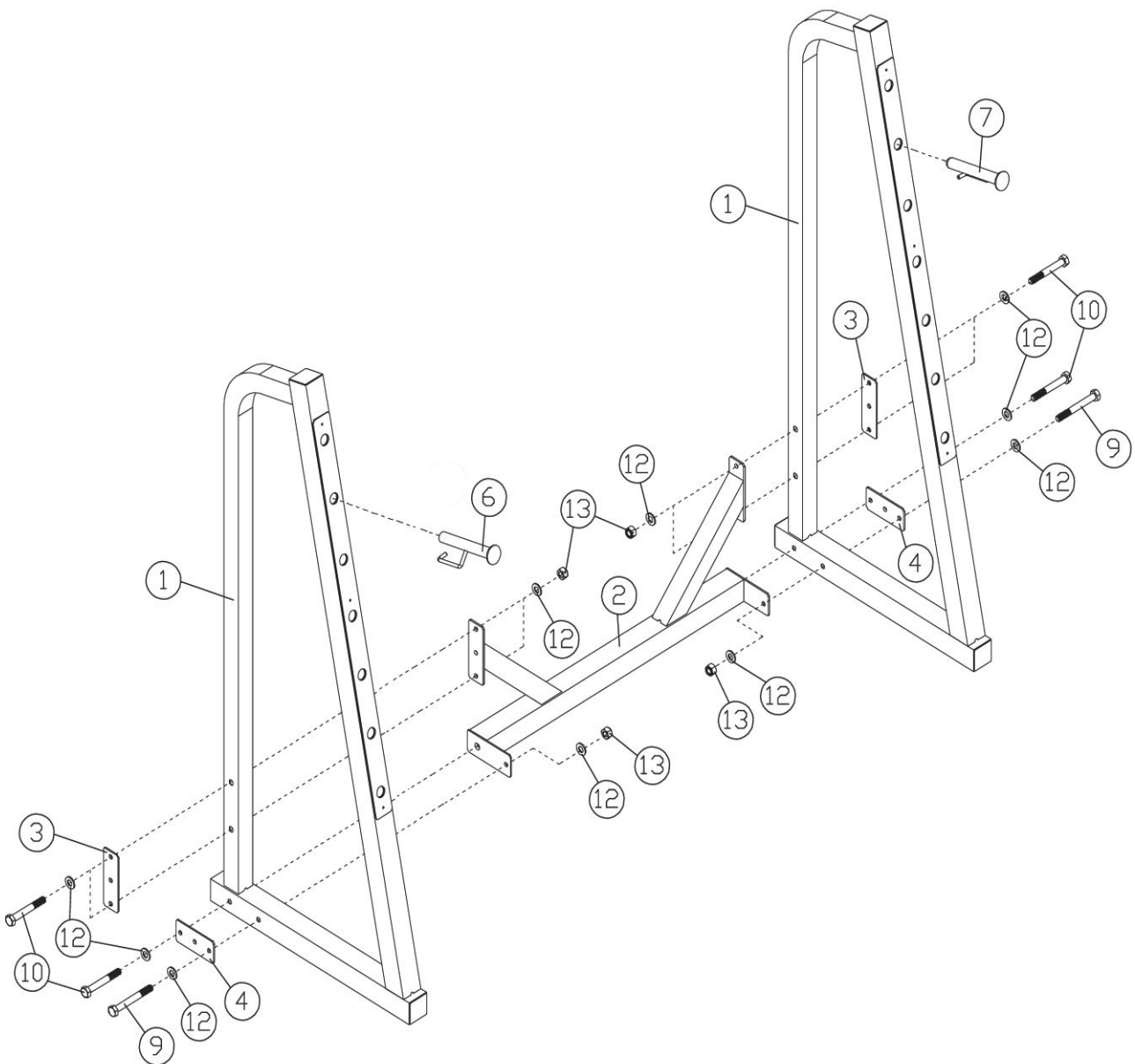

# Parts list

KEY NO.	DESCRIPTION	Q'ty
1	Upright Beam	2
2	Support Frame	1
3	Long Bracket	2
4	Short Bracket	2
5	Panel	2
6	Right Bar Catch	1
7	Left Bar Catch	1
8	□ 60 End Cap	6
9	M10×3 1/4" Bolt	2
10	M10×2 7/8" Bolt	6
11	Panel Screw	6
12	Ø 3/4" Washer	14
13	M10 Nut	6
14	φ 25 End Cap	2

